

FORESTRY MULCHERS

UMH/MEGA

Forestry mulcher for PTO tractors with fixed tooth rotor.

UMH/MEGA is a unique forestry mulcher. It is designed for the most powerful tractors available, and allows you to work large areas in a quick and effective way. The UMH/MEGA was built for operators seeking a

highly productive mulcher combined with an extremely efficient tiller. It can mulch trees up to 50 cm diameter and grind at a depth of 25 cm, all in one machine.



350-500 hp

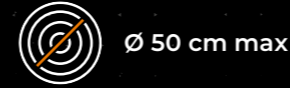

Ø 50 cm max



Depth 25 cm

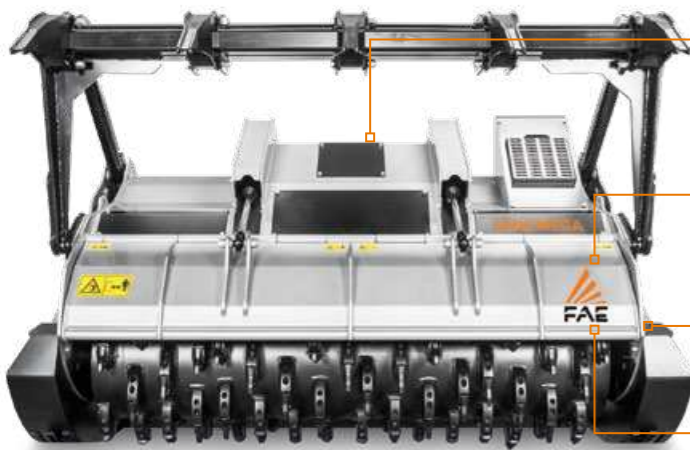

Three rows of forged and hardened interchangeable counter-blades for the longest working life while providing a finer product



Z style self-ranging system for the PTO drive shaft/gearbox helps keep the correct operating angle between the PTO shaft and the power take-off

Aggressive body design the protruding rotor allows more material to process without dragging

Inner anti wear clad plates FCP absorbs wear while protecting the frame



Standard hydraulic clutch transmission protects the transmission at PTO engagement for smooth starting and improves machine performance

Adjustable extended 3 point hitch fits perfectly with any type of tractor

Side transmission with belts in Poly-Chain® Carbon for longer lasting performance

MAIN OPTIONS



Hydraulically adjustable skids allow the rotor to penetrate deeply into the soil for grinding stumps and roots



W style self-aligning device between PTO drive shaft/gearbox allows the mulcher to work at several angles without damaging the PTO



Mechanical/hydraulic push frame guides and pushes material away from carrier



Additional ripper for push frame helps with the positioning of standing material while mulching

STANDARD EQUIPMENT

Hydraulic rear hood	Hydraulic clutch transmission
Inner anti wear clad plates FCP	Gearbox with freewheel
Adjustable extended 3 point linkage	Gearbox with oil cooling system
Enclosed machine body	PTO shaft
Centralized greasing hub	Bolted-on rotor shafts (in forged steel)
Hydraulic hoses integrated in the frame	Hydraulic top link
Cylinder protection	Z style self ranging system of the PTO drive shaft/gearbox
Inside lateral protection	Forged and hardened interchangeable counter-blades
Dual row protection chains	Third row of interchangeable forged and hardened counter-blades
Poly-Chain® belts transmission	

OPTIONS

Multiple tooth options	Mechanical guard frame
W style self-aligning device between PTO drive shaft/gearbox	Hydraulic guard frame
Hydraulically adjustable skids	Extra ripper for push frame
Special skids to go underground	

MODEL	UMH/MEGA 225	UMH/MEGA 250
Tractor (hp)	350-500	350-500
PTO (rpm)	1000	1000
Working width (mm)	2320	2560
Total width (mm)	2820	3060
Weight (kg)	5970	6320
Rotor diameter (mm)	910	910
Max shredding diameter (mm)	500	500
Max working depth (mm)	250	250
No. teeth type A/3+MH	94+2	106+2

Data refers to machine as standard. The technical data in this catalogue may be altered without prior notice.

ROTOR TYPE A



A/3
(standard)



A/3+HD
(option)



MH
(side scraper)